

VAM EIS

Designed for greater drilling capabilities



VAM EIS® is a high-torque connection that is fully intermateable with API connections but incorporates a double-shoulder tool joint design. As additional torque is applied, the pin nose makes contact with the internal shoulder. The internal shoulder absorbs the higher frictional load, providing the connection with improved torque capability.

VAM EIS high strength double shoulder connections from VAM Drilling set a new connection performance standard at cost efficiencies similar to that of API connections.

The additional torsional strength provides exceptional performance in the most difficult well conditions, such as highly deviated or extended reach wells. This design also benefits service life with a significantly greater wear capability.

VAM EIS is available in drill pipe sizes from 2-7/8" to 6-5/8" OD, including 5-7/8", and in a wide range of steel grades, including sour service and high strength.

The VAM EIS tool joint design provides:

Higher Torque

Using the VAM EIS connections with current API ODs and IDs results in torque capacity 50% percent higher (or more) than API.

Larger ID

Using VAM EIS improves hydraulic performance while maintaining the required torque.

Smaller OD

Slimmer profile than current API connections, while maintaining required strength, controlling torque and drag and improving fishability.

Extended Service Life

Using the VAM EIS with standard ODs and IDs results in an OD wear capability 30% higher than API. When combined with a 2" longer-than-standard tool joint it provides unbeatable service life.

Sour Service

A lower grade tool joint (105 ksi or even 95 ksi) exhibits the same level of torque as an API connection in 120 ksi, enabling optimum drilling parameters in sour environments.

Flexibility

Intermateable with API connections, new or used.

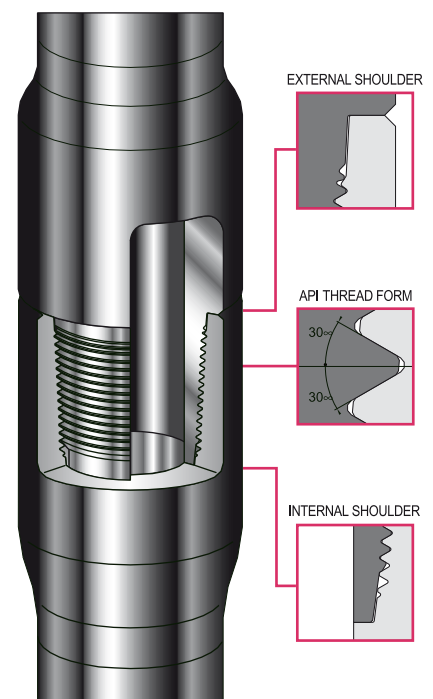

VAM DRILLING

Torque Benefit - VAM EIS® vs API

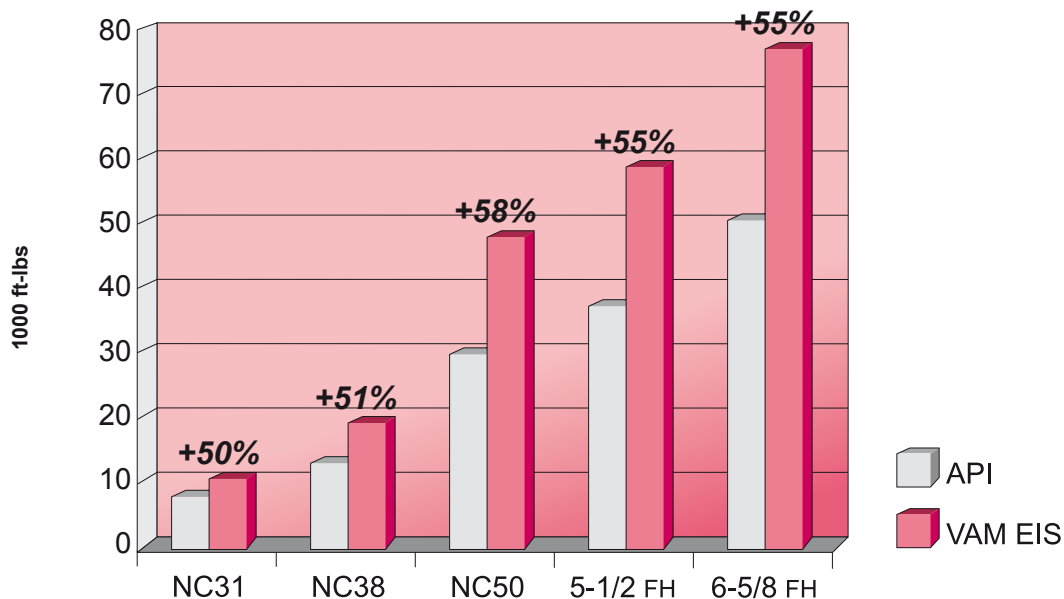

Note: Data based on API and VAM EIS connections. OD and ID were selected to be the same for comparative purpose.

Typical Tool Joint Data and Comparison

Pipe Size (in)	Connection		Tool Joint		Make-up Torque (ft-lbs)
	Type	Size	OD (in)	ID (in)	
2-7/8	API	NC31	4-1/8	2	7 890
	VAM EIS	NC31 VAM EIS	4-1/8	2	11 800
3-1/2	API	NC38	4-3/4	2-9/16	11 500
	VAM EIS	NC38 VAM EIS	4-3/4	2-9/16	17 000
4	API	NC40	5-1/4	2-9/16	16 600
	VAM EIS	NC40 VAM EIS	5-1/4	2-9/16	24 700
4-1/2	API	NC46	6-1/4	3	23 400
	VAM EIS	NC46 VAM EIS	6-1/4	3	36 100
5	API	NC50	6-3/8	3-1/2	26 700
	VAM EIS	NC50 VAM EIS	6-3/8	3-1/2	40 600
5-1/2	API	5 1/2 FH	7	4	33 400
	VAM EIS	5 1/2 FH VAM EIS	7	4	49 500
5-7/8	API	NA	NA	NA	NA
	VAM EIS	5 1/2 FH VAM EIS	7	3-3/4	58 300
6-5/8	API	6 5/8 FH	8	5	43 900
	VAM EIS	6 5/8 FH VAM EIS	8	5	64 700