



VAM[®] CDS

Designed for better drilling & compatibility



VAM CDS™ is a high-torque double-shoulder connection that is fully compatible with API and certain other double-shoulder connections available on the market.*

VAM CDS high strength double-shoulder connections from VAM Drilling set a new connection performance standard at cost efficiencies similar to API connections.

As additional torque is applied, the pin nose makes contact with the internal shoulder. The internal shoulder absorbs the higher frictional load, providing the connection with improved torque capability. In challenging well conditions, such as highly deviated or extended reach wells, the additional torsional strength of **VAM CDS** provides outstanding performance. In addition to that, the significantly higher durability of **VAM CDS** ensures a longer service life.

VAM CDS is available in drill pipe sizes from 2-7/8" to 6-5/8" OD, and in a wide range of steel grades, including Sour Service and high strength.

The VAM CDS tool joint design provides:

Higher Torque

Using VAM CDS connections with current API ODs and IDs results in torque capacity 50% higher (or more) than API.

Larger ID

Using VAM CDS improves hydraulic performance while maintaining the required torque.

Smaller OD

Slimmer profile than current API connections, while maintaining required strength, controlling torque and drag and improving fishability.

Extended Service Life

Using VAM CDS with standard ODs and IDs results in an OD durability 30% higher than API. When combined with a 2" longer-than-standard tool joint it provides unbeatable service life.

Sour Service

A lower grade tool joint (105 ksi or even 95 ksi) exhibits the same level of torque as an API connection in 120 ksi, enabling optimum drilling parameters in sour environments.

Flexibility

Intermateable with API connections, new or used as well as certain other double-shoulder connections available on the market.*

* Please contact your nearest VAM Drilling Office to confirm connection compatibility with CDS.

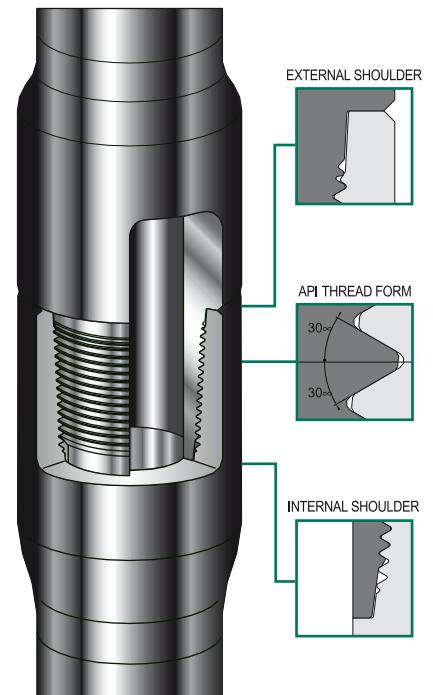

Torque Benefit - VAM CDS™ vs API

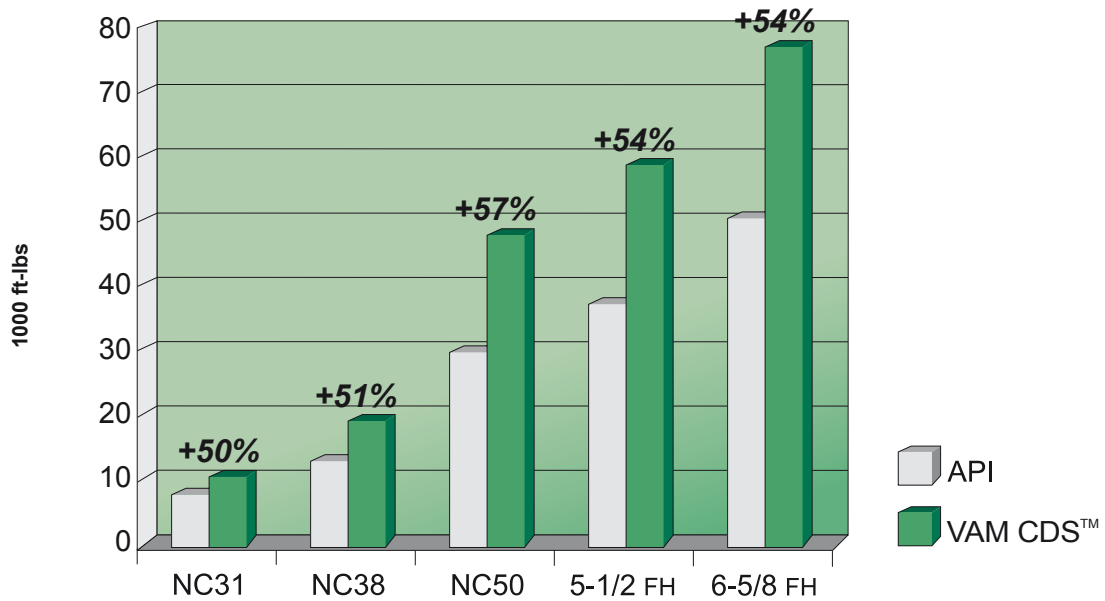

Note: Data based on API and VAM CDS connections. OD and ID were selected to be the same for comparative purpose.

Typical Tool Joint Data and Comparison

	API (120 ksi)	VAM CDS™ (130 ksi)
Tool Joint OD (in)	6 5/8"	6 5/8"
ID (in)	3 1/2"	3 1/2"
Torsional Yield (ft-lbs)	44 500	67 700
Make-up Torque (ft-lbs)	26 700	40 600